



Electromechanical Actuators



3405 Series
6405 Series
(115 Volt A.C. / 12 Volt D.C.)

**Installation, Operation
& Maintenance Instructions**

**Publication Part
No. SK-6405-100**

⚠ CAUTION!

This manual contains important information for the correct installation, operation and maintenance of the equipment described herein. All persons involved in such installation, operation, and maintenance should be thoroughly familiar with the contents. To safeguard against the possibility of personal injury or property damage, follow the recommendations and instructions of this manual and keep it for further reference.

⚠ WARNING!

The equipment shown in this manual is intended for industrial use only and should not be used to lift, support, or otherwise transport people.

SECTION I**GENERAL INFORMATION**

1-1 General	3
1-2 Industrial Use Only	3
1-3 Factory Preparation	3
1-4 Friction Disc Clutch	3
1-5 Warranty and Warranty Repair	3
Figure 1-1 Dimensions and Specifications	3

SECTION II Installation	4
--------------------------------	---

SECTION III**OPERATIONAL PRECAUTIONS**

3-1 A.C. Motor	5
3-2 Voltage Supply	5
3-3 Cevis Pins	5

SECTION IV**MAINTENANCE**

4-1 Lubrication	5
4-2 Required Tools	5
4-3 General Procedures	5
4-4 Disassembly	5
4-5 Assembly	6
Figure 4-1 Slip Clutch Assembly	7
Figure 4-2 Brake Coupling Alignment	8

SECTION V**ILLUSTRATED PARTS LIST**

Figure 5-1 Exploded Illustration	9
----------------------------------	---

SECTION VI

Figure 6-1 Wiring Diagram	10
---------------------------	----

1-1. General

This page provides instructions for operation and maintenance of Duff-Norton® 3405 and 6405 Series electro-mechanical actuators. To ensure efficient, long and satisfactory use of this unit, read and understand the information herein, and follow the instructions closely.

1-2. Industrial Use Only

The actuators described and illustrated in this manual are intended for industrial use only and should not be used to lift, support or otherwise transport people unless you have a written statement from Duff-Norton which authorizes the specific actuator unit, as used in your application, as suitable for moving people.

1-3. Factory Preparation

Each actuator is carefully assembled and tested at the factory to ensure that the electrical and mechanical components will function properly and that the actuator will lift its rated load. The motor current draw is checked to make certain that it is within Duff-Norton standards.

Every effort has been made to deliver this unit to you in its factory approved state. You should, however, carefully inspect the actuator for damage that may have occurred during transit.

1-4. Friction Disc Clutch

The friction disc clutch is set so that the actuator will lift its rated load, or a lighter load if so specified, but will slip should the actuator be run into a jamming position at the end of its travel. Thus, under overloads, or jamming conditions, the clutch will slip while the motor continues to run. If necessary, the clutch can be set to slip at a lighter load by connecting an ammeter in the line at the motor,

loading the actuator, and, while operating, loosening the clutch hex nut slightly until ammeter reads the required current draw. (See table below.) Clutch is not effective at loads of 50 pounds or less.

1-5. Warranty and Warranty Repair

Subject to the conditions stated herein, Duff-Norton will repair or replace, without charge, any parts proven to Duff-Norton's satisfaction to have been defective in material and workmanship. Claims must be made within one year after date of shipment. Duff-Norton will not repair or replace any parts that become inoperative because of improper maintenance, eccentric loading, overloading, chemical or abrasive action, excessive heat, or other abuse.

Equipment and accessories not of Duff-Norton's manufacture are warranted only to the extent that they are warranted by the manufacturer, and only if the claimed defect arose during normal use, applications and service. Equipment which has been altered or modified by anyone without Duff-Norton's authorization is not warranted by Duff-Norton. EXCEPT AS STATED HEREIN, DUFF-NORTON MAKES NO OTHER WARRANTIES, EXPRESS OR IMPLIED, INCLUDING WARRANTIES OR MERCHANTABILITY AND FITNESS FOR A PARTICULAR PURPOSE.

If you have any questions concerning warranty repair, please contact Duff-Norton.

Authorization for return must be received from Duff-Norton before returning any equipment for inspection or warranty repair.

2-1. To install the actuator, simply support and secure it

WITH 115 V. 60 HZ AC MOTOR

3405 Series Applied Load (lbs.)	6405 Series Applied Load (lbs.)	Speed (in/min)		Amps	
		Standard Motor	Optional High Speed Motor	Standard Motor	Optional High Speed Motor
100	100	42	80	2.40	4.50
200	200	41	75	2.45	4.60
250	300	39	73	2.50	4.65
N/A	400	37	70	2.55	4.70
N/A	500	35	68	2.60	4.80

WITH 12 V. DC MOTOR

3405 Series Applied Load (lbs.)	6405 Series Applied Load (lbs.)	Speed (in/min)		Amps	
		Standard Motor (MPD-6405)	Optional High Speed Motor (HMPD-6405)	Standard Motor	Optional High Speed Motor
100	100	68	145	6	21
200	200	60	132	10	28
250	300	52	120	13	36
N/A	400	42	-	17	-
N/A	500	32	-	22	-

DUTY CYCLE CHART

3405 Series Applied Load (lbs.)	6405 Series Applied Load (lbs.)	# Duty Cycle (inches per hour)			
		AC Motor		DC Motor	
		Standard 28-33 mfd Capacitor	High Speed 64-77 mfd Capacitor	Standard DC Motor	High Speed DC Motor
100	100	600	490	2800	1350
200	200	575	485	1750	1000
250	300	550	470	1050	700
N/A	400	525	465	650	-
N/A	500	500	450	350	-

Total inches travel (up and down) per hour with equally timed intervals between cycles.

NOTE: Some actuator external surface temperatures may reach 230° during use at or near maximum duty cycle. All ratings are nominal and are based on actuator being broken-in for approximately 2500 inches of travel.

SECTION I DIMENSIONS AND SPECIFICATIONS

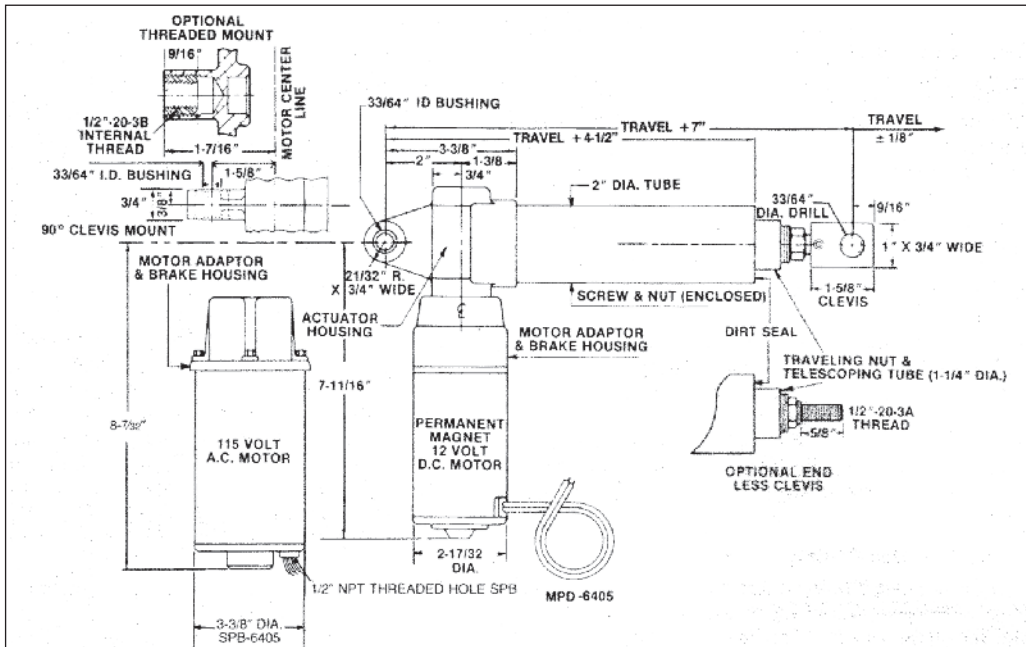

FIGURE 1-1

Note: Dimensions are subject to change without notice.

SECTION II INSTALLATION

with a single pin through one clevis end, secure it to its load with a second clevis pin, and then use the appropriate wiring diagram (AC or DC, Figure 2-1 or 2-2) to connect the actuator to your power source.

2-2. Avoid using a low voltage supply for the actuator. All wiring, switches, and other electrical components must be of sufficient capacity to carry the required current.

2-3. The translating tube is not keyed, and must be restrained from rotating.

2-4. The axes of the clevis pins should be parallel so that the actuator can pivot without binding. A few drops of oil should be applied to the clevis pins on installation and periodically thereafter.

2-5. External wires for customer hookup are color coded as to direction of travel (see wiring diagrams, Figure 2-1 or 2-2).



CAUTION

To protect the actuator and prevent damage from overtravel, it is recommended that travel limiting switches be incorporated in the installation.

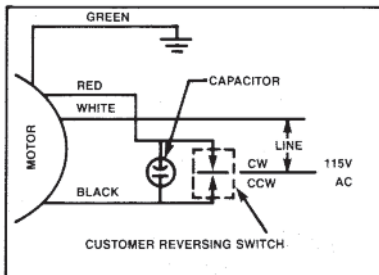

Minimum voltage: 103.5
 CW = Retract; CCW = Extend
 Low Voltages reduce the Load Rating of the Actuator

FIGURE 2-1

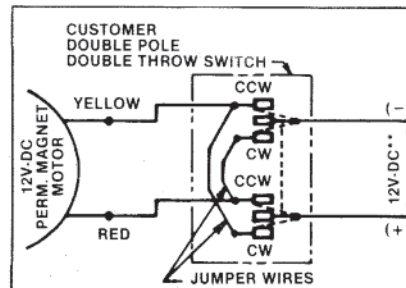

*22 amps running; 30 amps stall
 CW = Retract; CCW = Extend

FIGURE 2-1

SECTION III OPERATIONAL PRECAUTIONS

3-1. A.C. Motor

This motor is an intermittent duty type motor having a five minute rating. Since the motor draws almost the same amperage at no load as at full rated load, it only takes 5 minutes of continuous running, regardless of how light the load may be, before the thermal overload relay cuts out. It then takes about 10 minutes before the motor cools sufficiently for the thermal relay to close. Make sure that the duty cycle to which the actuator is subjected is not too severe for the motor. The rear end bell of the motor has a rubber grommet, which when removed, exposes a hole threaded for 1/2" NPT (SPB).

3-2. Voltage Supply

Avoid using a low voltage supply for the 115 Volt AC motor.

Avoid using a voltage supply lower than 11 volts D.C.

3-3. Clevis Pins

The axes of the clevis pins should be parallel so that the actuator can pivot without binding. A few drops of oil should be used on the clevis pins.

SECTION IV MAINTENANCE

4-1. Lubrication

Duff-Norton recommends the use of the following lubricant in conjunction with proper maintenance procedures of this unit: Exxon Ronnex Extra Duty #1.

4-2. Required Tools

A bearing puller and press, soft jaw table clamp and common hand tools are required for proper disassembly and assembly.

4-3. General Procedures

Duff-Norton recommends following these procedures during disassembly and assembly:

1. Tag critical parts to facilitate reassembly.
2. Mark mating surfaces to ensure proper meshing.
3. Clean and lubricate parts as required.
4. All seals must be replaced at time of rebuild.
5. All screws, washers and other small common parts must be replaced if mutilated in any way.

4-4. Disassembly

Disassemble the 6405 Series Mini-Pac™ actuator as follows while referring to Figure 5.1. Read instructions thoroughly before disassembling.

1. Clamp housing (13) in vice - use soft jaws.
2. A. D.C. Unit
 - I. Loosen screws (1) (back end of motor (3) from motor adaptor (9) (do not remove screws from motor).
 - II. Remove motor (3) from motor adaptor (9) (use screw driver to separate motor end from adaptor), Taking care that motor end bells do not separate from motor shell.

B. A.C. Unit

- I. Remove socket head cap screws (1) and lock washers (2) from motor (3) and remove motor (3) from motor adaptor (9).
3. D.C. Unit - Remove brake springs (7) from motor adaptor (9) and brake cam (6) from pinion (12).
4. Remove screws (8) from housing (13) and remove motor adaptor (9).
5. Remove pinion (12) and bearing (11) from housing.
6. Remove retaining ring (10) from pinion (12) and remove (11) from pinion (12).
7. Clamp housing (13) clevis end in vice (use soft jaws), remove set screw (17) from housing (13).
8. Unscrew outer tube (22) from housing (13) and remove translating tube (32), screw (25), gear (19) and outer tube (22) from housing (13).
9. Remove translating tube (32) from outer tube (22) by slipping outer tube (22) over translating tube (32) towards clevis end (35).
10. Remove seal (24) from outer tube (22) and press guide bushings (23) from outer tube (22) and press guide bushing (23) from outer tube (22) (seal guide bushing need not be removed unless damaged).
11. Support screw (25) end taking care not to damage gear (19) teeth. With a 3/16 diameter punch, drive pin (18) from screw (25), remove gear (19) bearing (20) and washer (21) from screw (25).
12. Thread screw (25) part way out of nut (27) and check screw (25) and nut (27) for wear (there should not be excessive lay between screw and nut thread). If screw or nut are not excessively worn, the disassembly of screw (25), nut (27) and translating tube (32) will not be necessary unless clutch must be replaced.
13. Pins (31) should be approximately 3/32 above translating tube (32) OD. Grind pins (31) flush with OD of

translating tube (32).

14. Using 3/16 diameter punch drive pins (313) far enough into the lifting nut (27) to just clear the translating tube (32) wall. (Do not drive pins against OD of screw (25).) Remove nut (27) with screw (25) from translating tube (32).

15. Remove screw (25) from nut (27).

16. Remove pins (31) from nut (27) by driving pins (31) remaining distance into ID of nut (27).

17. Remove stop pin (26) from screw (23).

18. Drive pin (34) from clevis end (35).

19. While restraining hex cap screw (28) from rotating, remove clevis (35) from cap screw (28). (Cap screw can be restrained from turning by using a 3/4 hex socket with long extension into translating tube (32) ID.)

20. Remove lock nut (33) from cap screw (28).

21. Remove Belleville spring washers (30) and thrust washer (29).

22. Remove cap screw (28), Belleville washers (30) and thrust washer (29) from ID of translating tube (32).

23. Drive pin (4) from motor (3) shaft and remove coupling (5) and remove damper (36) from I.D. of coupling. Note if coupling is not damaged, it need not be removed.

24. A.C. unit - ball brake disassembly. Remove set screws (7c) from ball housing (6) and remove springs (7b) and balls (7a) and remove drive coupling (5) from ball housing (6).

25. If bushing (16) in housing (13) is worn remove.

26. If bushing (14) in housing (13) clevis is worn, press bushing (14) out.

27. If bushing (15) in housing (13) is worn, press bushing out.

DISASSEMBLY IS COMPLETE.

4-5. Assembly:

1. A. Install damper (36) into coupling (5) I.D. and assemble drive coupling (5) with hole in motor (3) shaft and install pin (4).

B. A.C. Unit Only

I. Assemble ball housing (6) on drive coupling (5) (line up ball cavities with groove in coupling, assemble balls (7a), spring (7b) into ball cavity and thread set screw (7c) into ball housing (6), adjust set screws (7c) until torque required to turn motor (3) shaft and coupling (5) is 22 oz./in. to 28 oz./in., while restraining ball housing (6) from rotating. (note set screw (7c) will be approximately flush with OD of ball housing (6).)

2. Assemble bearing (11) on pinion (12) and install retaining ring (10) on pinion (12).

3. Apply Loctite retaining compound (or equal) to OD of bushing (15) and install in housing (13) (assemble into housing (13) end opposite side of housing with (4) holes for mounting motor adaptor (9).

4. Press bushing (14) in housing (13) clevis.

5. Press bushing (16) in housing (13).

6. Install pinion (12) bearing (11), retaining ring (10) into housing (13).

7. Assemble motor adaptor (9) onto housing (13) holding in place with screws (8).

8. Press bushing (23) into outer tube (22).

9. Install seal (24) in outer tube (22) (seal scraper should be facing inward).

10. Apply a generous coat of Shell Darina EP2 grease to thrust washer (30) and assemble thrust washer (30) and Belleville washers (29) on hex cap screw (28) (see figure 4-1 for proper installation of washer).

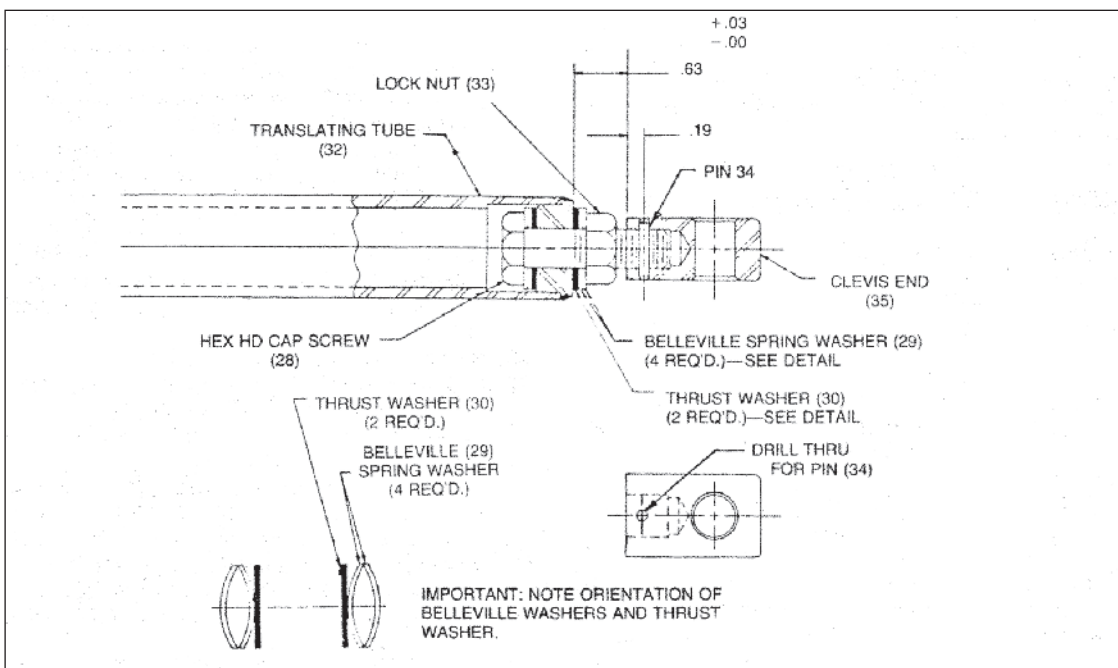

**FIGURE 2-1
SLIP CLUTCH ASSEMBLY**

11. Install hex cap screw (28), washer (30) and Belleville washers (29) into ID of translating tube (32) (use 3/4 hex socket with extra long extension).
12. With hex cap screw (28) threads extending out of translating tube (32) end, apply a generous coat of Exxon Ronnex Extra Duty #1 grease to thrust washer (30) and assemble thrust washer (30), Belleville washers (29) on hex cap screw (28). (See figure 4-1 for proper installation of washers.)
13. Assemble lock nut (33) on hex cap screw (28), torque lock nut (33) down to 30 in./lbs.
14. Assemble clevis (35) on hex cap screw (28). Drill 1/8 hole thru clevis end and hex hex cap screw (28) and lock in place with pin (34) (see figure 4-1). Note: Set slip torque at final assembly for desired slip load.
15. Assemble nut (27) on screw (25). (Flange of nut (27) towards turned end of screw (25).)
16. Install stop pin (26) into screw (25) taking care to center pin.
17. Fill translating tube (32) approximately half full with Exxon Ronnex Extra Duty #1 grease.
18. Assemble nut (27) into translating tube (32) (align holes in translating tube with holes in nut). Install pins (31) (pins should be 1/32 inch above OD of tube). New pins should be used.
19. Assemble washer (21) on screw (25).
20. Assemble bearing (20) on gear (19) and assemble on screw (25) and install pin (18) (pin should be centered when assembled). Take care not to damage gear teeth.
21. Clamp housing (13) in vice (use soft jaws gear cavity up.) Fill cavity approximately to centerline of pinion (12) with Exxon Ronnex Extra Duty #1 grease.
22. Assemble translating tube (32), bearing (20) and gear

(19) assembly into housing (13) taking care not to damage gear (19) teeth. (Rotate pinion (12) while assembling to be sure of proper mesh of gear (19) teeth and pinion (12) thread).

23. Grease OD of translating tube (32) with Exxon Ronnex Extra Duty #1.

24. With translating tube (32) extended approximately 3-1/2" to 4" from washer (21), assemble outer tube (22) on translating tube (32) and thread outer tube (22) into housing (13), against bearing (20) (torque in place at 40 foot pounds plus or minus 10 foot pounds).

25. Spot drill outer tube (22) thru set screw (17) hole (use drill slightly smaller than ID of thread). Remove chips and install set screw (17) and lock in place against outer tube (22).

26. A. A.C. Unit

- I. Align keyway in ball housing (6), and coupling (5) flats with key in motor adaptor (9) and flats of pinion (13), assemble motor (3) on motor adaptor (9) and secure in place with socket head cap screws (1) and lock washers (2).

B. D.C. Unit

- I. Assemble brake cam (6) on pinion (12).
- II. Install brake spring (7) into motor adaptor (9) (see figure 4-2).
- III. Taking care that motor (3) end bells do not separate from motor (3) shell, align drive coupling (5) pins as shown in figure 4-2 and assemble motor (3) to motor adaptor (9) holding in place with screws (1).

ASSEMBLY IS COMPLETE.

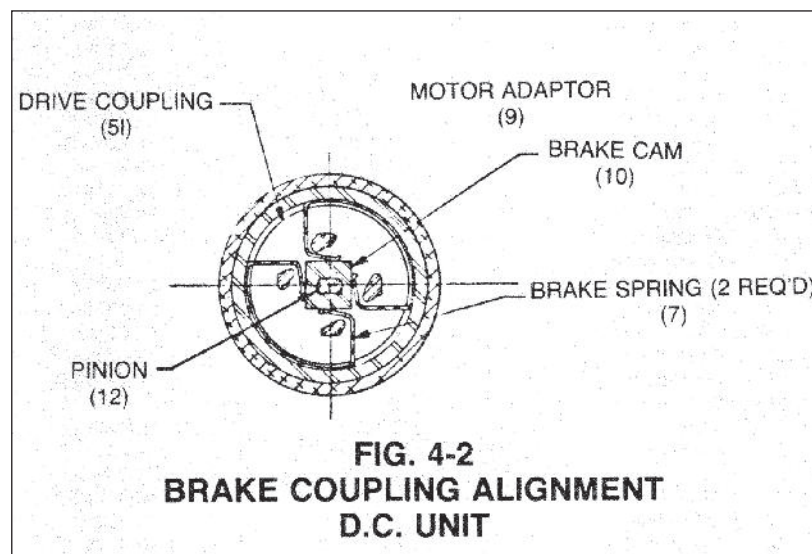

SECTION V
ILLUSTRATED PARTS LIST

Parts List for Duff-Norton 3405 and 6405 Series with Slip Clutch

Index	Part Name	MPD 6405 (DC)		SPB-6405 (AC)	
		MPD 3405 (DC)		SPB-3405 (AC)	
		Qty. Req'd	Part No.	Qty. Req'd	Part No.
1	Screw			4	S-49-94
2	Lock Washer			4	H-4081-P
3	Motor	1	SK-6405-22	1	SK-6405-14-2
3	Motor (High Speed)	1	SK-2374-43	1	SK-6505-32-1
4	Pin (Coupling)	1	S-50-68	1	H-5249
5	Coupling	1	SK-2374-20	1	SK-6505-150
6	Brake Cam	1	SK-2374-19		
6	Ball Housing			1	SK-6405-26
7	Spring	2	SK-2374-18		
7a	Set Screw			4	S-7-121
7b	Compression Screw			4	SK-6505-39
7c	Roller Ball			4	SK-6405-20
8	Screw	4	SK-2374-25	4	SK-2374-25
9	Motor Adaptor	1	SK-2374-2	1	SK-6505-149
10	Retaining Ring	1	SK-2374-8	1	SK-2374-8
11	Bearing	1	SK-2374-5	1	SK-2374-5
12	Pinion	1	SK-2374-3	1	SK-2374-3
13	Housing St'd	1	SK-2374-1	1	SK-2374-1
13	Housing 90°	1	SK-2374-79	1	SK-2374-79
13	Housing Th'd	1	SK-6505-15	1	SK-6505-15
14	Bushing (Clevis)	1	SK-6405-4	1	SK-6405-4
15	Bushing	1	SK-2374-10	1	SK-2374-10
16	Bushing	1	SK-2374-11	1	SK-2374-11
17	Set Screw	1	S-7-94	1	S-7-94
18	Pin (Gear)	1	H-5167	1	H-5167
19	Gear	1	SK-2374-4	1	SK-2374-4
20	Bearing	1	SK-2374-6	1	SK-2374-6
21	Washer	1	SK-2374-9	1	SK-2374-9
22	Outer Tube	1	SK-6405-12-*	1	SK-6405-12-*
23	Guide Bushing	1	SK-2374-26	1	SK-2374-26
24	Seal	1	SK-2374-16	1	SK-2374-16
25	Screw	1	SK-2374-12-*	1	SK-2374-12-*
26	Pin (Stop)	1	H-5159	1	H-5159
27	Nut	1	SK-2374-13	1	SK-2374-13
28	Hex Head Cap Screw	1	SK-2374-70	1	SK-2374-70
29	Belleville Spring Washer	4	SK-2374-71	4	SK-2374-71
30	Thrust Washer	2	SK-2374-72	2	SK-2374-72
31	Pin (Nut)	2	H-5160	2	H-5160
32	Translating Tube	1	SK-6405-25-*A	1	SK-6405-25-*A
33	Hex Lock Nut	1	SK-2374-78	1	SK-2374-78
34	Pin (Clevis)	1	H-5169	1	H-5159
35	Clevis End	1	SK-6405-11	1	SK-6405-11
36	Damper			1	SK-6505-152

*Dash No. Equal to Travel of Actuator

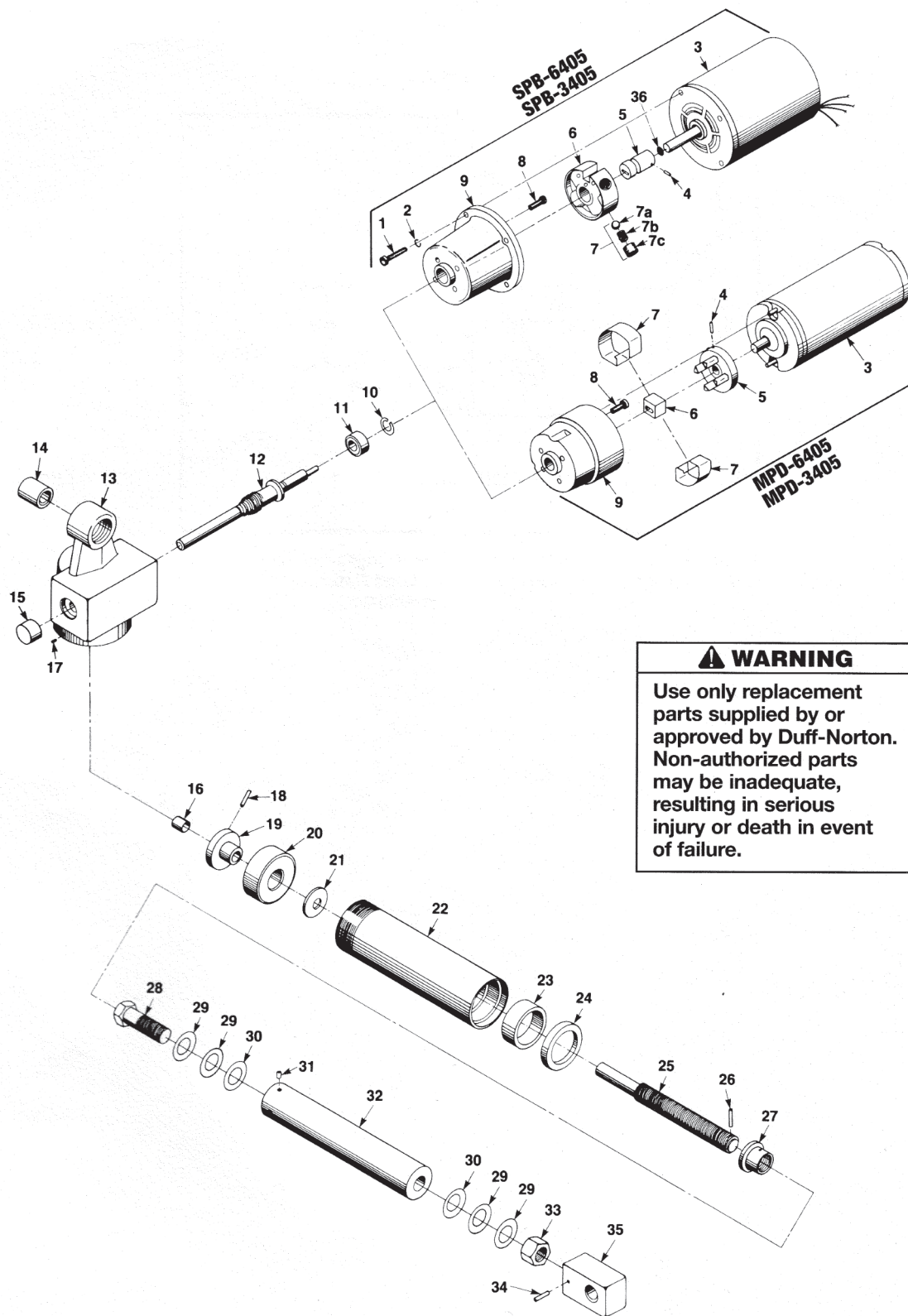

⚠ WARNING

Use only replacement parts supplied by or approved by Duff-Norton. Non-authorized parts may be inadequate, resulting in serious injury or death in event of failure.

SECTION VI
TECHNICAL ILLUSTRATIONS

FIGURE 6-1 LIMIT SWITCH WIRING DIAGRAM

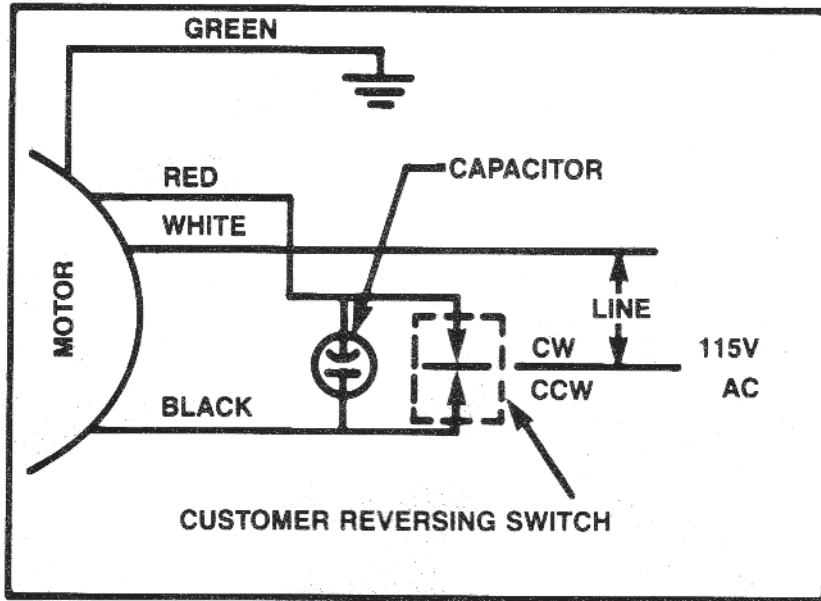

Minimum voltage: 103.5
CW = Retract; CCW = Extend

Low Voltages reduce
the Load Rating of
the Actuator

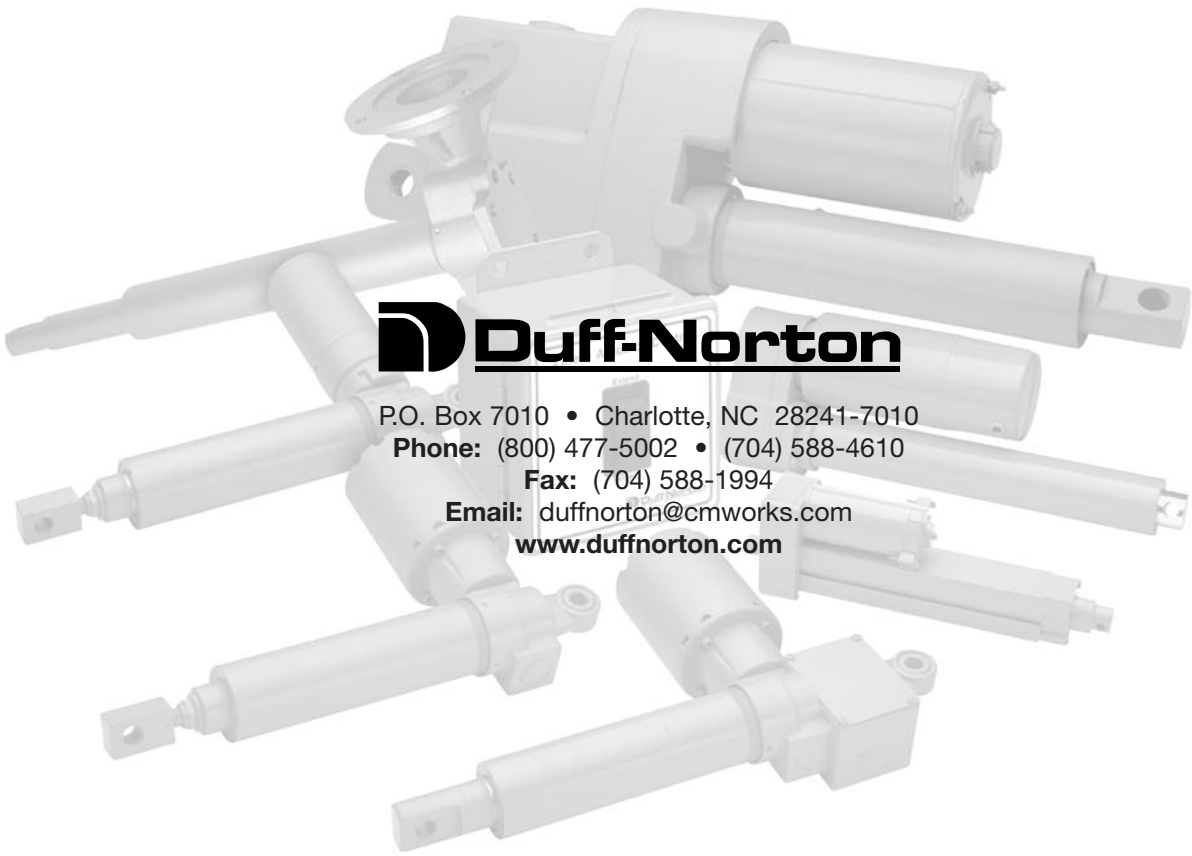

**Duff-Norton**

P.O. Box 7010 • Charlotte, NC 28241-7010

Phone: (800) 477-5002 • (704) 588-4610

Fax: (704) 588-1994

Email: duffnorton@cmworks.com

www.duffnorton.com



ISO 9001:2000