

100 kN (MD Series)

| | |
|---------------------------------|-----------------------|
| Maximum operating pressure | 70 MPa |
| Maximum output on the push side | 100 kN |
| Effective area on the push side | 14.52 cm ² |
| Cylinder internal diameter | φ 43 |
| Maximum output on the pull side | 51.3 kN |
| Effective area on the pull side | 7.45 cm ² |
| Cylinder system | Double-acting |
| Coupler connection port size | Rc3/8 |

• The piston is plated.

For cylinder and pump selections, see page 54.

Model code structure

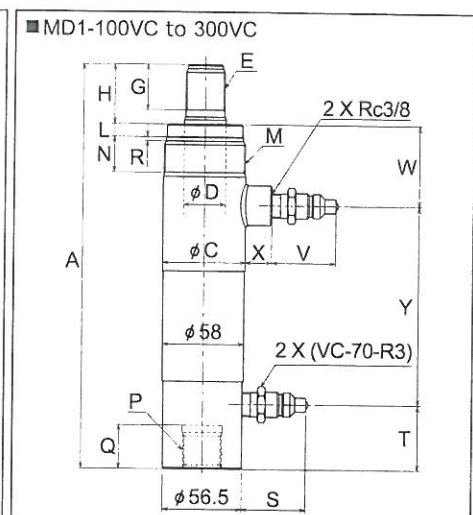
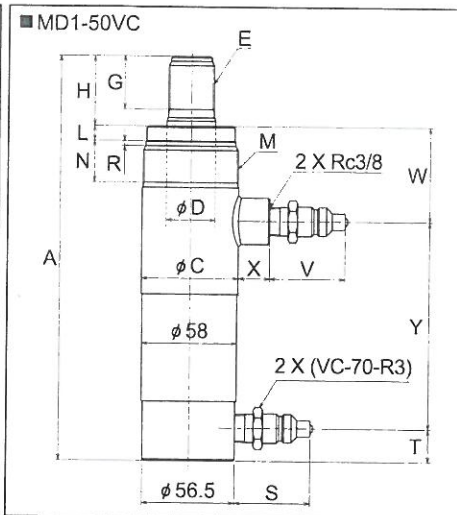
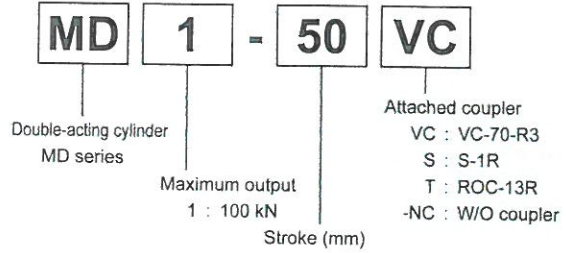

Specifications

| Model | | MD1-50 | MD1-100 | MD1-150 | MD1-200 | MD1-250 | MD1-300 |
|-----------------------------------|-----------------|--------------------------------|---------------------------------------|---------|---------|---------|---------|
| Stroke | mm | 50 | 100 | 150 | 200 | 250 | 300 |
| Minimum overall length | A | 244 | 320 | 370 | 420 | 470 | 520 |
| Cylinder external diameter | φ C | 59 | | | | | |
| Piston diameter | φ D | 30 | | | | | |
| Piston thread size | E | M28 x 2 | | | | | |
| Piston thread length | G | 32 | | | | | |
| Piston protrusion length | H | 42 | | | | | |
| Length of piston stop ring | L | 9 | | | | | |
| Collar thread size | M | M58 x 2 | | | | | |
| Collar thread length | N | 25 | | | | | |
| Base thread size | P | M28 x 2 | | | | | |
| Base thread depth | Q | 31 | | | | | |
| Incomplete thread length | R | 3 | | | | | |
| Coupler protrusion length | VC-70-R3 | S (push side) V (pull side) | S (push side) ≈ 46 V (pull side) ≈ 46 | | | | |
| | S-1R | | S (push side) ≈ 53 V (pull side) ≈ 53 | | | | |
| | ROC-13R | | S (push side) ≈ 49 V (pull side) ≈ 49 | | | | |
| Coupler position on the push side | T | 20 | 46 | | | | |
| Coupler position on the pull side | W | 57 | | | | | |
| Boss length on the pull side | X | 20 | | | | | |
| Distance between the ports | Y | 125 | 175 | 225 | 275 | 325 | 375 |
| Required oil volume | cm ³ | 73 | 146 | 218 | 291 | 365 | 436 |
| Approx. weight | kg | 4.0 | 5.2 | 6.0 | 6.8 | 7.6 | 8.3 |

Compatible attachments

| Attachment location | Cylinder parts | MD1-50 | MD1-100 | MD1-150 | MD1-200 | MD1-250 | MD1-300 |
|---------------------|----------------|--------------|---------|---------|---------|---------|---------|
| Piston thread | Cap | R-10PM | | | | | |
| | Tilt saddle | R-10SP | | | | | |
| | Piston base | RB-10M | | | | | |
| | Clevis | CLF-10-1 (2) | | | | | |
| Collar thread | Flange | 10FM | | | | | |
| Base thread | Cylinder base | CB-10M | | | | | |
| | Clevis | CLM-10-1 (2) | | | | | |