



# Pascal 2005 SD (5 m<sup>3</sup>/h)

Two-stage rotary vane pump of 5 m<sup>3</sup>/h, Standard version



Similar Image

## Pascal 2005, SD version, 1-phase motor, 180-254 V, 50 Hz/60 Hz, CE/UL/CSA

SD, I, C1 versions are delivered with mineral oil, and C2 versions are prepared for operation with PFPE oil but fluid must be ordered separately

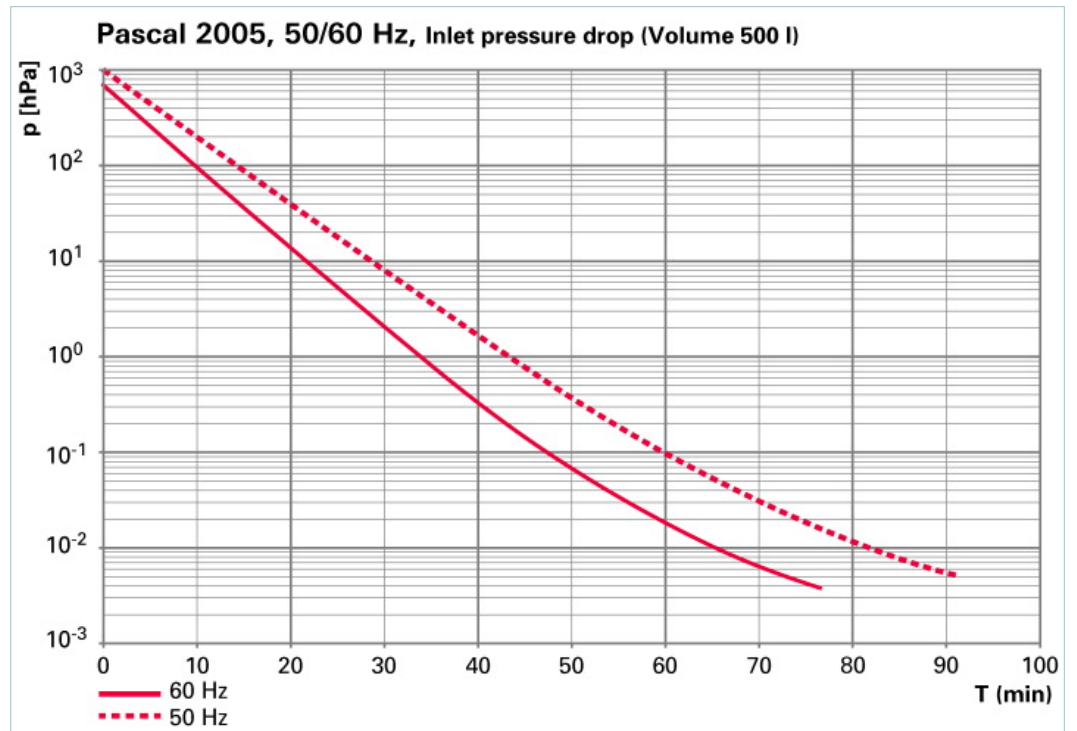
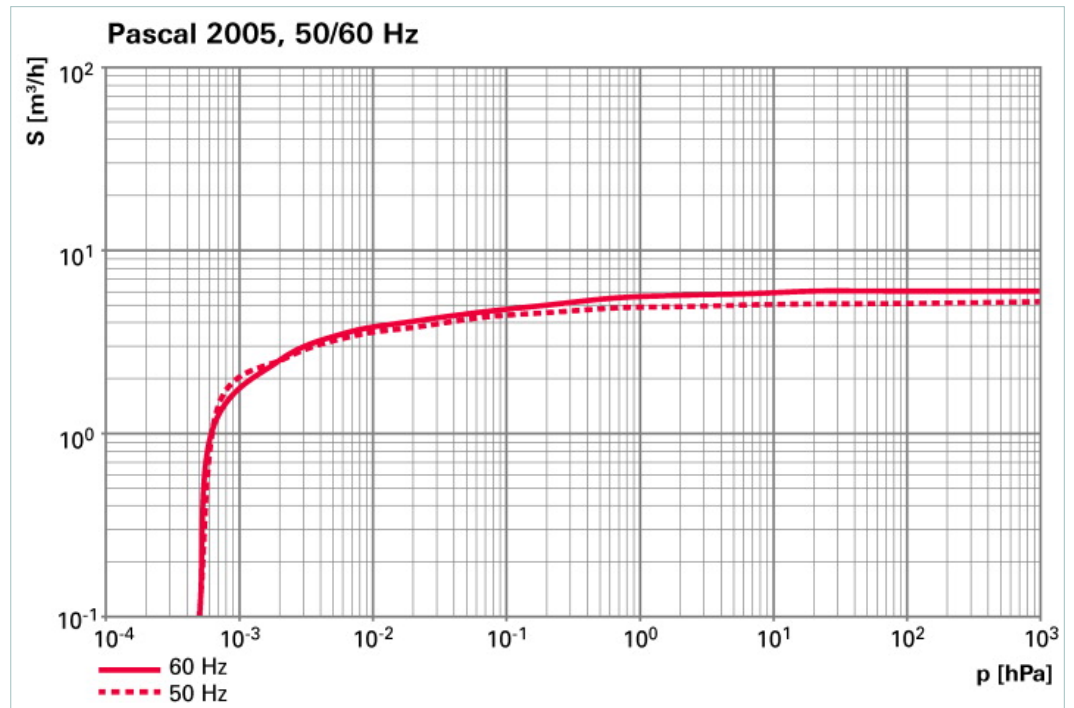

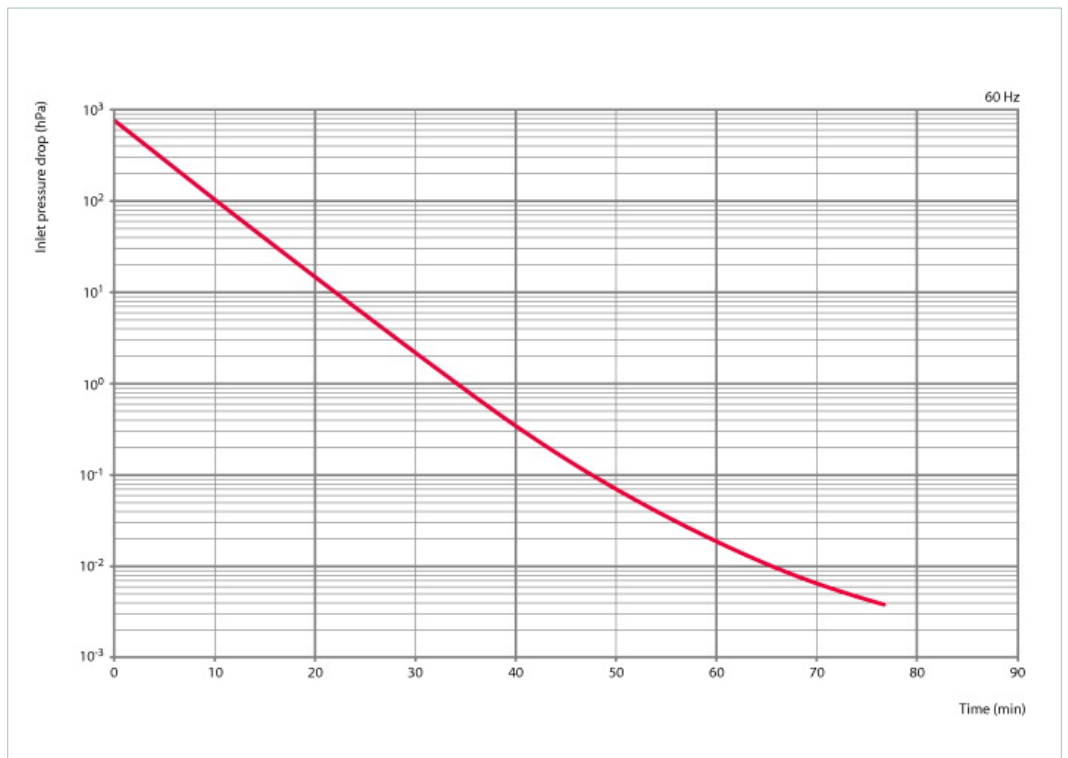

### Dimensions

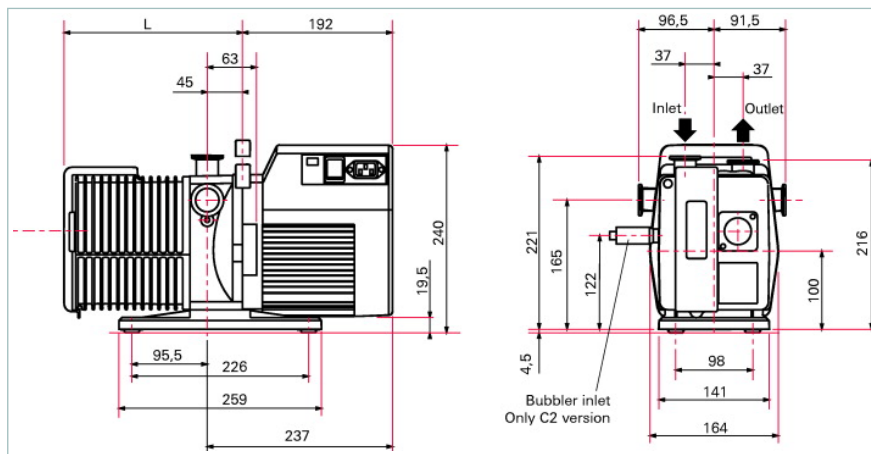

L 228 mm

Technical Data	Pascal 2005, SD version, 1-phase motor, 180-254 V, 50 Hz/60 Hz, CE/UL/CSA
Flange (in)	DN 25 ISO-KF
Flange (out)	DN 25 ISO-KF
Mains requirement: voltage 50 Hz	180-254 V
Mains requirement: voltage 60 Hz	180-254 V
Motor version	1-phase Motor
Operating fluid	Mineral oil
Pumping speed at 50 Hz	5 m <sup>3</sup> h
Pumping speed at 60 Hz	6 m <sup>3</sup> h
Rated power 50 Hz	0.45 kW
Rated power 60 Hz	0.55 kW
Ultimate pressure	5 · 10 <sup>-4</sup> hPa   3.75 · 10 <sup>-4</sup> Torr   5 · 10 <sup>-4</sup> mbar
Ultimate pressure with gas ballast	1 · 10 <sup>-2</sup> hPa   7.5 · 10 <sup>-3</sup> Torr   1 · 10 <sup>-2</sup> mbar
Version	Standard
Weight	25 kg   55.12 lb

**Technical Data**

Pascal 2005, SD version, 1-phase motor, 180-254 V, 50 Hz/60 Hz, CE/UL/CSA

Ultimate pressure according to PNEUROP

**Order number**Pascal 2005 SD (5 m<sup>3</sup>/h)**205SDMHEM****Accessories****Accessories**

Automatic gas ballast AGB 4, 100 V, 50/60 Hz	<b>104088</b>
Automatic gas ballast AGB 4, 115 V	<b>104087</b>
Automatic gas ballast AGB 4, 200 V, 50/60 Hz	<b>104366</b>
Automatic gas ballast AGB 4, 230 V, 50/60 Hz	<b>104086</b>
Automatic gas ballast AGB 4, 24 VDC	<b>104089</b>
Condensate trap CT 25	<b>104201</b>
Inlet dust filter DFT 25	<b>104202</b>
Liquid nitrogen trap LNT 25 P1	<b>786346</b>
Liquid nitrogen trap LNT 25 S	<b>104197</b>
Oil drain kit ODK 1	<b>104360</b>
Oil drain kit ODK 2, 100 V, 50/60 Hz	<b>104363</b>
Oil drain kit ODK 2, 115 V, 60 Hz	<b>104362</b>
Oil drain kit ODK 2, 200 V, 50/60 Hz	<b>104364</b>
Oil drain kit ODK 2, 230 V, 50/60 Hz	<b>104361</b>
Oil drain kit ODK 2, 24 VDC	<b>104365</b>
Oil level switch OLS 4	<b>104376</b>
Oil mist eliminator OME 25 HP	<b>104199</b>
Oil mist eliminator OME 25 HP+	<b>108341</b>
OME 25 M, oil mist filter for pumping speeds of up to 12 m <sup>3</sup> /h	<b>PK Z40 157</b>
OME 25 S Oil mist eliminator	<b>104200</b>
Sorption trap ST 25 S	<b>104107</b>
<b>Accessories UnoLine</b>	
KLF 025, cold trap	<b>PK Z80 006</b>
SAS 25, dust separator, DN 25 ISO-KF, polyester filter	<b>PK Z60 508</b>
URB 025, catalytic trap, 115 V	<b>PT U10 761</b>
URB 025, catalytic trap, 230 V	<b>PT U10 760</b>

## **VACUUM SOLUTIONS FROM A SINGLE SOURCE**

Pfeiffer Vacuum stands for innovative and custom vacuum solutions worldwide, technological perfection, competent advice and reliable service.

## **COMPLETE RANGE OF PRODUCTS**

From a single component to complex systems:

We are the only supplier of vacuum technology that provides a complete product portfolio.

## **COMPETENCE IN THEORY AND PRACTICE**

Benefit from our know-how and our portfolio of training opportunities!

We support you with your plant layout and provide first-class on-site service worldwide.

Are you looking for a  
perfect vacuum solution?  
Please contact us:

All data subject to change without prior notice.